



Quick Installation Guide

Mega Series KSY -90KW-110KW

Poonam petrol pump, KSolare Technology Park, Sr.No. 62,
Hissa No.03, Mangdewadi, Pune, Maharashtra 411046

Enquiry Email: Sales@ksolare.com

Service Email: service@ksolare.com

Contact: 853011222

Follow Us On





5G Mega Series 90KSY, 100KSY, 110KSY String Type PV Inverter Quick Installation Guide

CAUTION

- The contents of this manual are subject to irregular updates due to product upgrades or other reasons. Unless otherwise agreed, this manual is only used as guidance. All statements, information and recommendations in the document do not constitute any express or implied warranty.
- In any case, guidance in this manual cannot replace safety warnings and instructions on user manuals and product fuselage.
- All operations of the equipment must be carried out by professionals. Operators should be fully familiar with the composition, working principles and standards of the whole PV system.
- Before installing the equipment, check whether the delivery is complete and whether the body has obvious external damage according to the "packing list". If there are any missing items or any damage, please contact the distributor.
- The following two situations occur and are not covered by the warranty.
 - ☒ Remove the tamper-evident label;
 - ☒ Equipment damage caused by failure to store, handle, install, and use the equipment in accordance with the requirements of this manual and the user manual.

1. Product Introduction

Scope of Supply

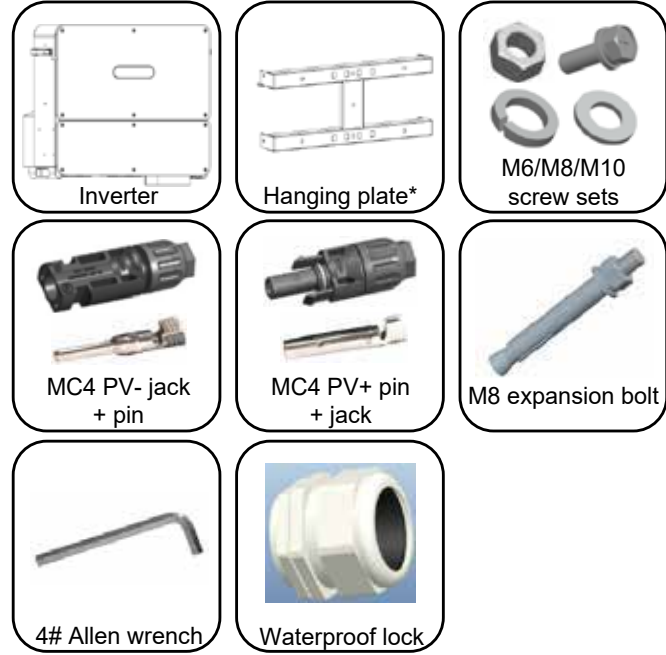

*The hanging plate is fixed on the back of inverter.

The documents including:
 Quick Installation Guide (this manual)
 List of Accessories
 Inspection Report
 Certification

For the model and number of the accessories, please refer to the *List of Accessories*.

This figure is only for reference; please refer to the actual product.

Inverter front

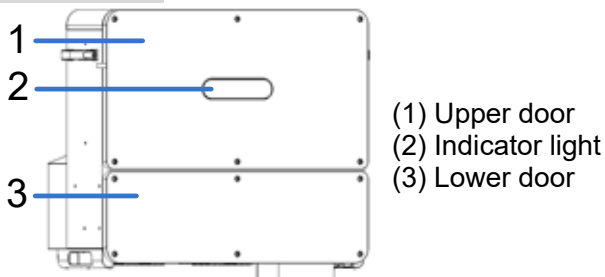

Port description

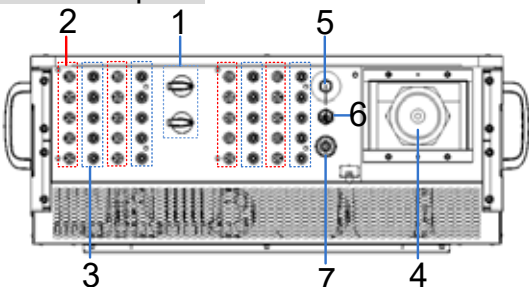

- (1) DC SWITCHES (2) PV- terminals
 (3) PV+ terminals (4) AC output terminal
 (5) Wi-Fi/GPRS interface (6) Anti-backflow interface
 (7) RS485 interface

2. Installation Requirements

Installation Environment

Please install the inverter in a well ventilated environment, avoid direct sunlight, rain and snow.

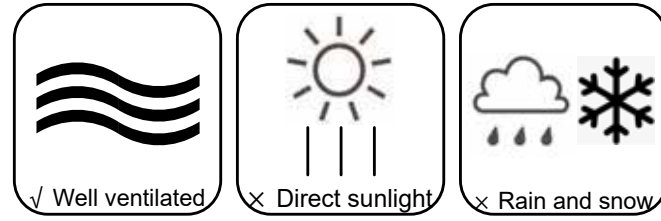

Ambient Temperature

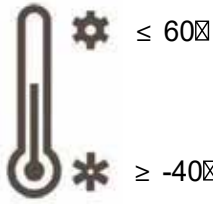

Relative humidity

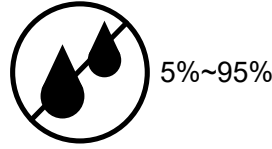

(The inverter can reach the best working condition when the temperature is lower than 40°C)

Inverter and hanging plate size

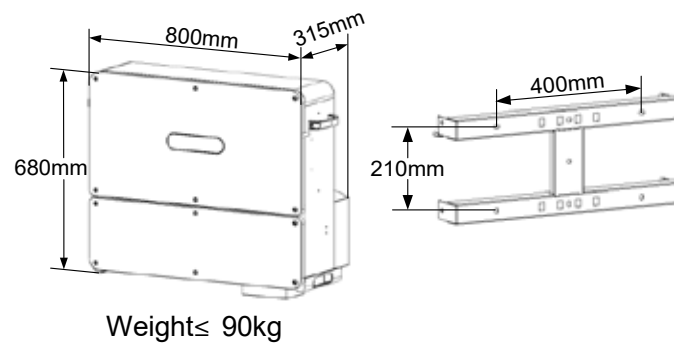

Installation Space

The installation space of single inverter is as following:

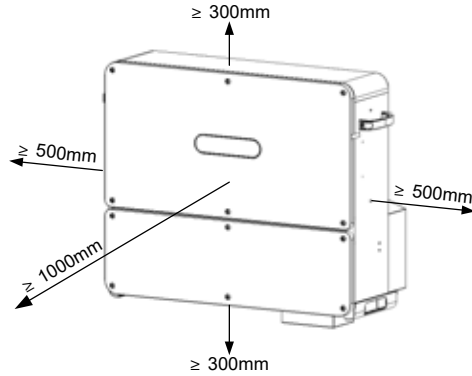

When installing multiple string inverters in a same surface, the side by side installation is recommended.

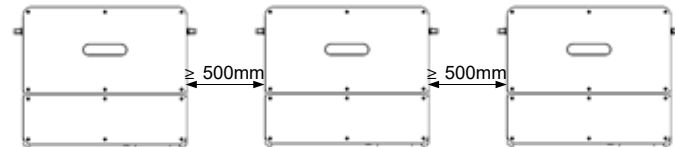

When installing multiple string inverters in two lines, the triangle installation is recommended.

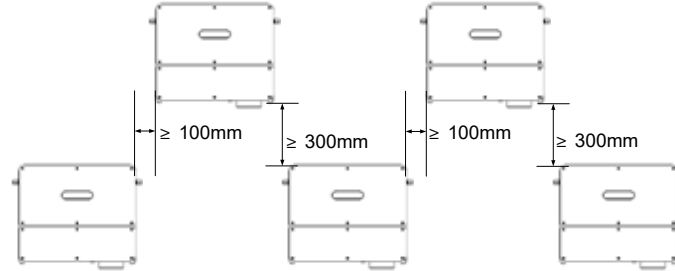

Please install it vertically or tilt it backward at most 15° to facilitate the heat dissipation of the inverter. Do not install the inverter at an angle (forward, backward, or sideways), horizontally, or upside down.

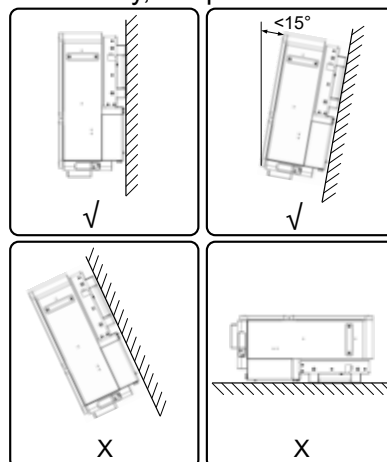

3. Inverter Installation

Installation Steps

- Unscrew the 4 fixing screws and keep them in a safe place, and then take out the hanging plate.

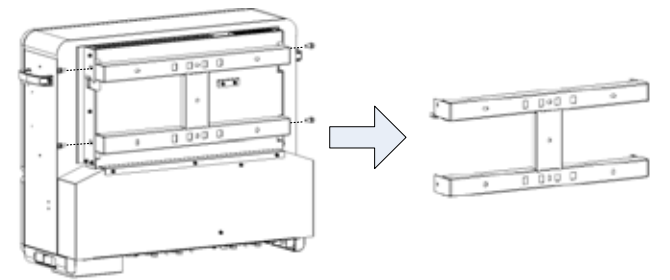

- According to the installation environment, choose a suitable installation method to install the hanging plate.

Wall/Bracket Mounting

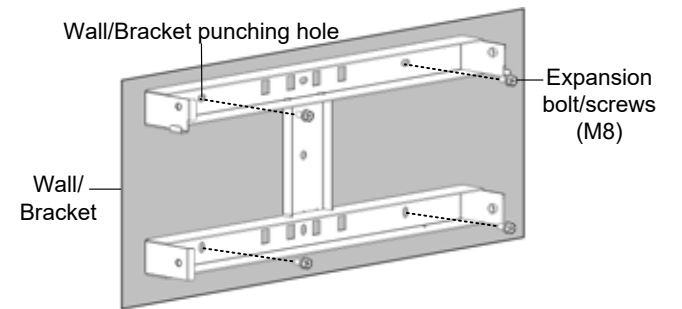

Screw Rod Mounting

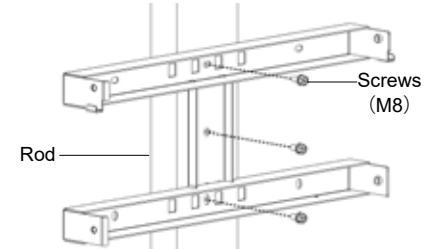

Hoop Rod Mounting

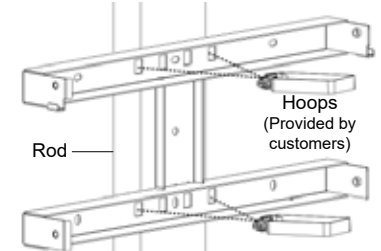

- Hang the inverter on the hanging plate.

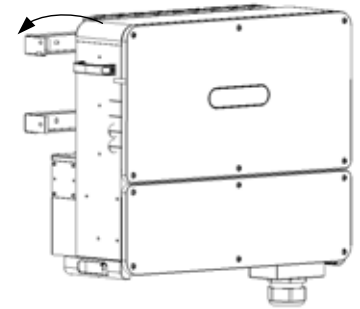

- Reinstall the 4 fixing screws removed in the first step.

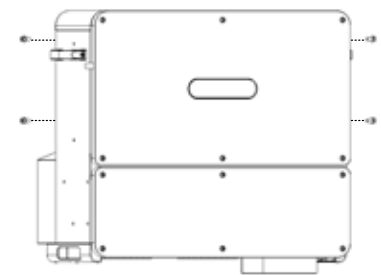

4. Electrical Connections

DANGER

- When connecting cables, do not operate live and follow the relevant requirements in the Inverter's Manual.
- Before connecting the cable, please complete the following preparations so as not to cause bodily injury.
 - Disconnect the inverter DC switch. Ensure that the inverter is in shutdown state and attach warning signs.
 - Confirm the positive and negative pole of the input cable and mark it well. Make sure the connection between input cable and PV cluster is broken.
 - It is confirmed that the open circuit voltage of PV cluster does not exceed the specified limit.
 - Confirm that the corresponding AC box circuit breaker is in a state of disconnection.
- When connecting the input cable, ensure that the positive and negative poles of the input cable correspond to the positive and negative poles of the PV terminals of the series inverter.

☒ Cable Selection

Name	Recommended Cable Specifications
PV branch input cable	Industry general PV cable, model: PV1-F It is recommended to use a cable with a cross-section of 4.0 mm ² for each PV+ and PV- branch.

Name	Recommended Cable Specifications
AC output cable	4 core outdoor cable (A, B, C, N) or 3 core outdoor cable (A, B, C) Recommended cross sectional area of conductor (copper):70 mm ²
RS485 communication cable	It is recommended to use a special communication cable or 4-core or 2-core shielded twisted pair cable with a cross-sectional area of not less than 0.75 mm ² .
PE ground cable	It is recommended to use at least one grounded dedicated cable with a cross-sectional area of 35 mm ² .

☒ Note:

- The AC output has only 1 waterproof locks with a specification of 65mm~70mm. When the screw is locked, use the sleeve to calibration.
- The RS485 communication cable has only one waterproof lock and the size is 18mm~25mm.

☒ Output side cable connection

- Crimping the OT terminal. Users need to prepare the OT terminals themselves. The OT terminal model of PE is M6, and the model of AC is M10.
 - Strip the front end of the cable core.

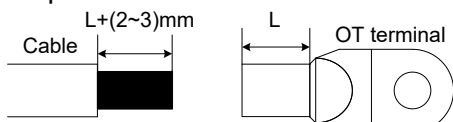

- Put on the heat shrink tubing and OT terminal.

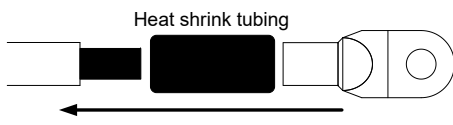

- Crimp the OT terminal.

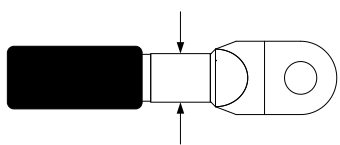

- Move the heat shrink tubing forward to cover the seam.

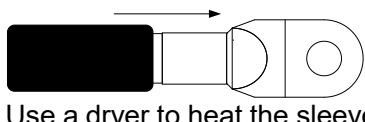

- Use a dryer to heat the sleeve to make it tight.

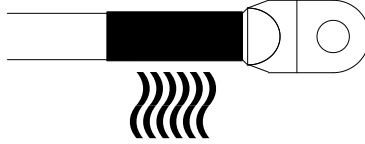

- Ground connection:

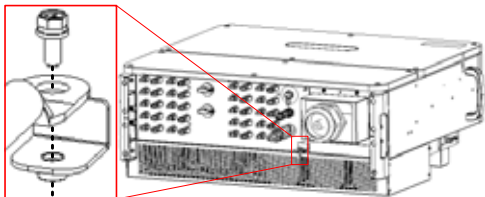

Note: The ground cable must be reliably connected to the grounding bar.

- DC output cable connection :

- Remove the lower door by 4# Allen wrench.

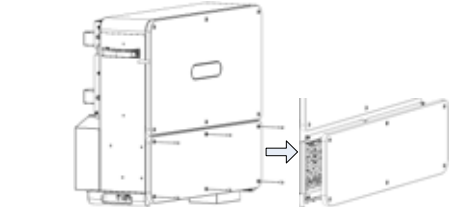

- Tear off the AC output protective film and install the waterproof lock.

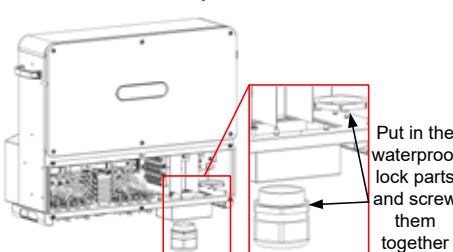

- Screw off the locking cap of the AC output waterproof lock.

- The AC cables are connected to A, B, C and N of the AC terminal row in turn, and the fastening torque is 8N*m. Fasten the locking cap after completion.

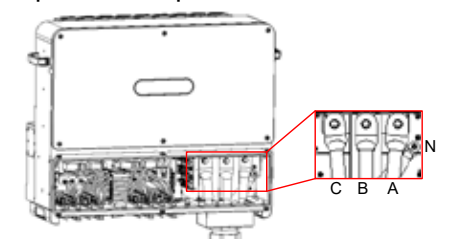

☒ PV Input Cable Connection

- Crimp MC4 terminal:
 - Confirm the positive and negative terminals of the input cable and mark them.

Note: Please do not judge by the color of the cable only, be sure to refer to the actual measurement.

- Stripping with a wire stripper;

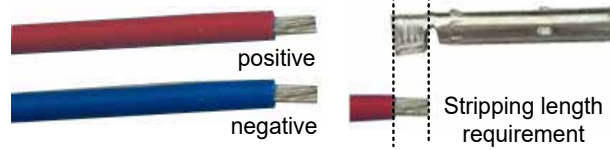

- Press the cable together with the corresponding core according to the correct polarity.

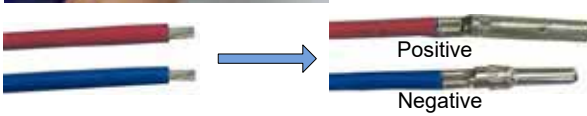

- Insert the core into the male and female ends of the MC4 connector and tighten the connector back cover according to the correct polarity.

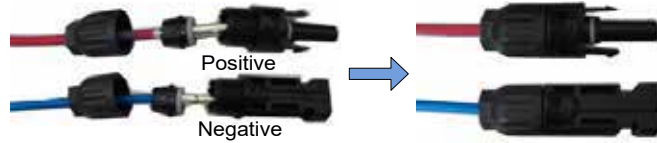

- Remove the sealing plugs of the input terminals at the bottom of the inverter. Connect the positive and negative terminals of each input cable to the PV+ and PV- input terminals of the inverter one by one. Insert it until you hear a "click".

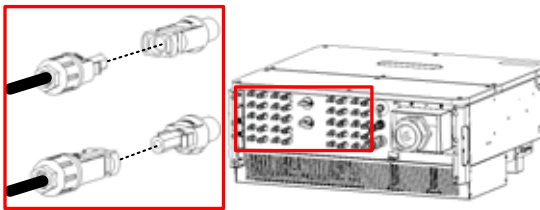

- If there are unconnected input terminals, please confirm that the unconnected input terminals remain sealed by the plug.

☒ RS485 Communication Cable Connection

The RS485 interface and anti-backflow interface are located on the bottom of the machine. The 8-pin terminal is for RS485 network and the 4-pin terminal is for the anti-backflow function.

- Crimp the 485 terminal. Users need to prepare the terminals themselves, and the terminals model needs to match the 485 cable selected. (The 8-Pin terminal needs to match GTVE10008 terminal.)
 - Strip the front end of the cable core.

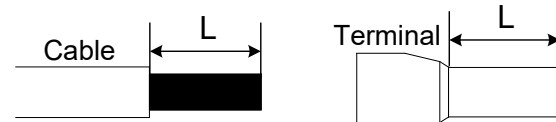

- Insert the terminal and crimp.

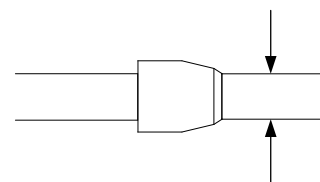

- Take out the connector from accessories and loosen the shell of the connector.
- Pass the cables through the shell

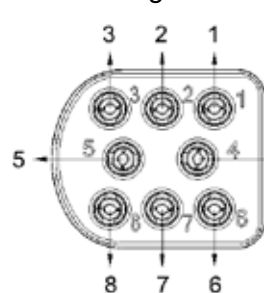

RS485 network 8-PIN terminal PIN feet

Footnote	Definition
1	RS485+
2	PE
3	RS485-
4	Terminal Resistance

5	Terminal Resistance
6	RS485+
7	PE
8	RS485-



Anti-backflow 4-PIN terminal PIN feet

Footnote	Definition
1	RS485+/ Terminal Resistance
2	PE
3	RS485-
4	Terminal Resistance

- Install the terminal to the bottom of the machine. Tighten the connector shell. The connection of multiple inverters is suggested to be connected in series in the following diagram.

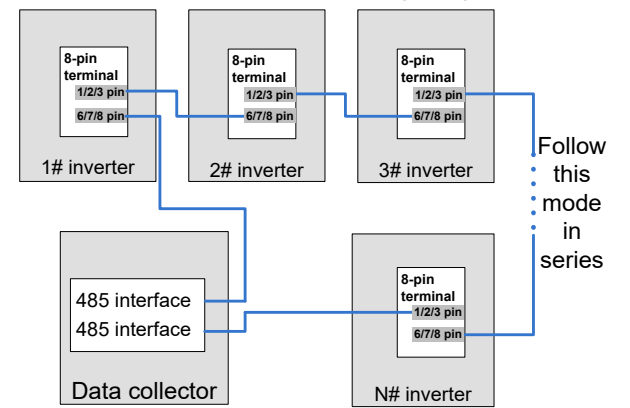

5. Post-installation Check

1. Confirm that the inverter is securely installed in place	☒
2. Check if the ground wire is properly connected, whether the connection is reliable and secure, and ensure that there is no open-circuit or short-circuit	☒
3. Check that the output cable is properly connected, that the connection is reliable and secure, and that there is no open-circuit or short-circuit.	☒
4. Check whether the DC input cable connection polarity is correct, whether the connection is reliable and secure, and ensure that there is no open-circuit or short-circuit.	☒
5. Check if the RS485 communication cable connection is correct and reliable.	☒
6. Check if the inverter's lower door panel is replaced and the door panel screws are tightened.	☒
7. Check if the DC input terminals that are not needed are sealed	☒

6. LED indicators Description

Indicator	Status	Meaning
POWER	Light on	Both PV side and grid side are normal
	Light flash	Grid side is normal, PV side is abnormal
	Light slow flash	PV side is normal, grid side is not connected
	Light off	Both PV side and grid side are not connected
RUN	Light on	Inverter is in operation
	Light off	Inverter is not in operation
COM.	Light slow flash	Communication is normal
	Light off	Communication is abnormal
ALARM	Light slow flash	Prompt warning
	Light flash	Abnormal warning
	Light on	Fatal warning

Ksolare Energy Private Ltd.
 Factory & Marketing Office
 Ksolare Technology Park Sr.No.62,
 Hissa No.03, Mangdewadi, Pune-Satara
 Road, Katraj, Pune-411046. (MH-India)

KSolare

Poonam petrol pump, KSolare Technology Park, Sr.No. 62,
Hissa No.03, Mangdewadi, Pune, Maharashtra 411046

Enquiry Email: Sales@ksolare.com

Service Email: service@ksolare.com

Contact: 8530111222

Follow Us On

